

**LOCKS 660/720-II/76M/GENERATION
E-760/770/790/79M/79T/RT
WITH MECHANICAL KEY OVERRIDE:**

HOW TO ATTACH THE LEVER HANDLE TO THE LOCK OUTSIDE HOUSING



- The following instructions must be completed on the outside housing before affixing the entire unit to the door.
- **If the lever is not assembled with the key in position shown in fig 8 & 9 the inside mechanism of the lock could be damaged if the lever is rotated and forced.**
- Check the functionality of the lock with the door open.

Lock Components

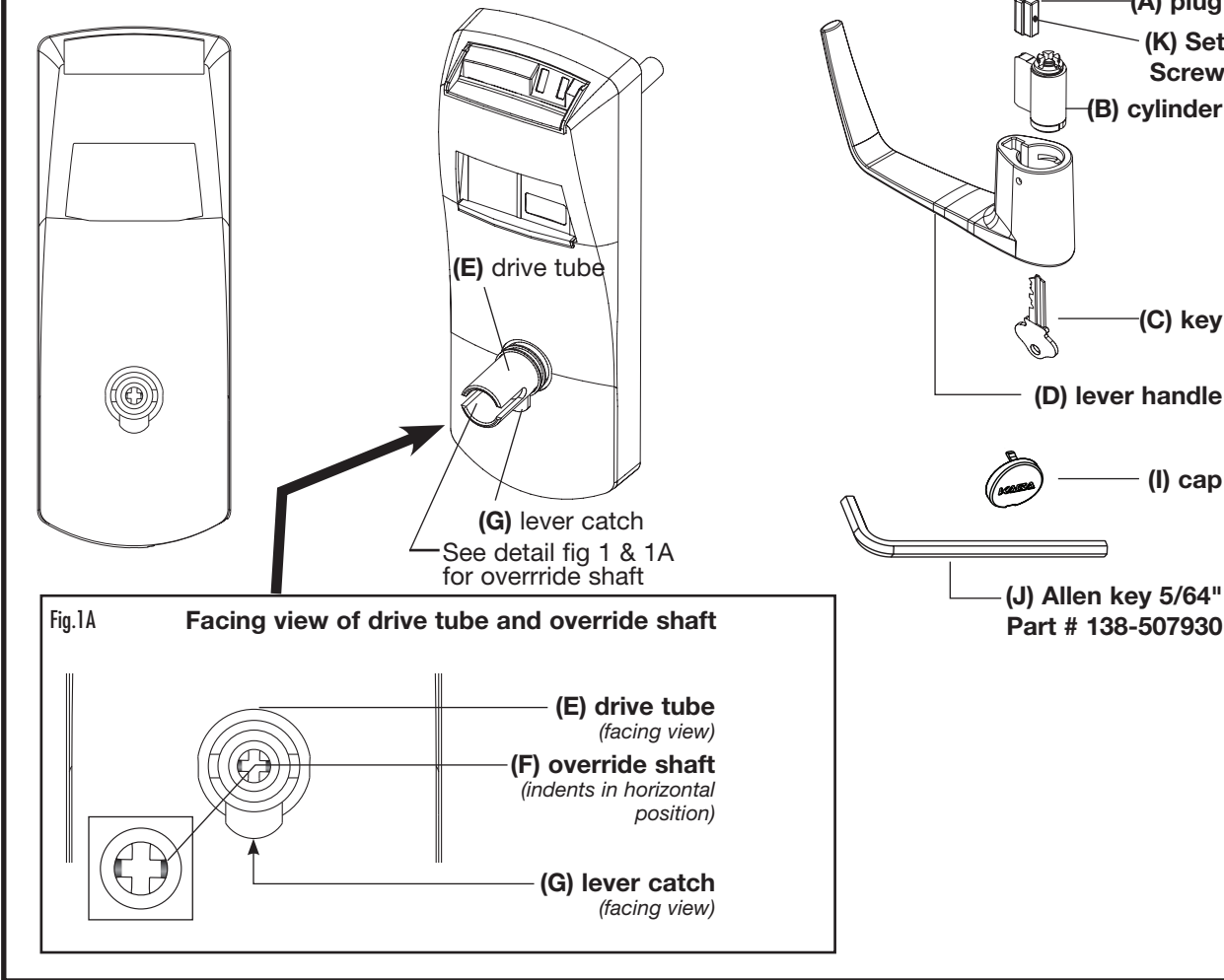

To assemble the lever handle:

1. Insert the key (C) into the cylinder (B) to be used as a tool (H) (see fig 1) to rotate override shaft (F) (see fig 2).

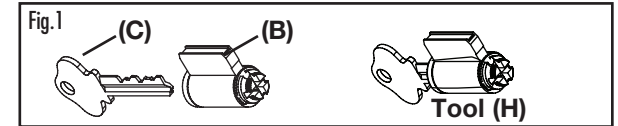

2. Insert the Tool (H) into the override shaft (F) and turn the key clockwise until it stops, making sure after removing tool (H) that the small indents (seen in Fig. 2) are in a vertical position approx.

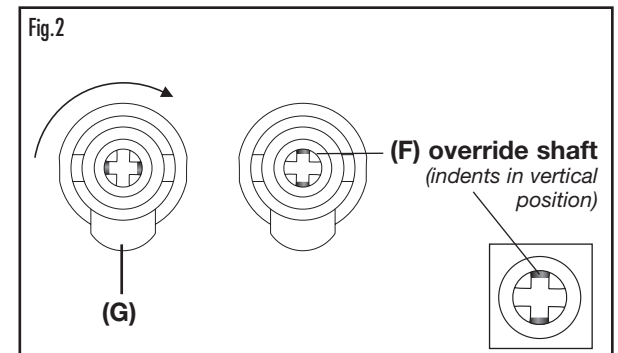

3. Push the lever catch (G) in to be flush with drive tube (E) diameter. Now the lock is ready to receive outside lever assembled with cylinder (B) (see fig.3)

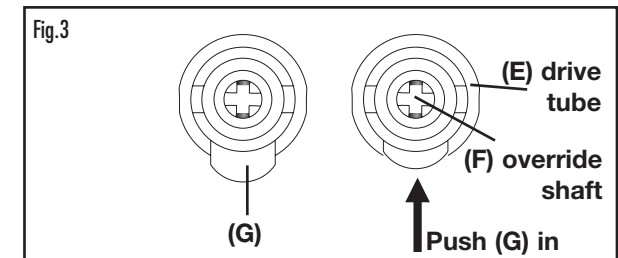

NOTE: To upgrade an electronic override lock to a lock with mechanical override, change the existing spring of the inside trim assembly with the new spring included.

The key override itself does not retract the latch. Turn the key clockwise until it stops, release the key and turn the lever to retract the latch.



4. Insert cylinder (B) without key into lever handle as shown below

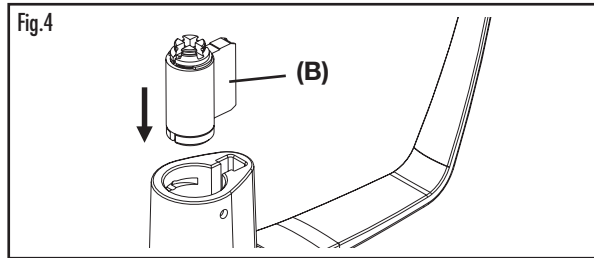

5. Insert plug (A) including Set Screw (K) into lever handle (D)

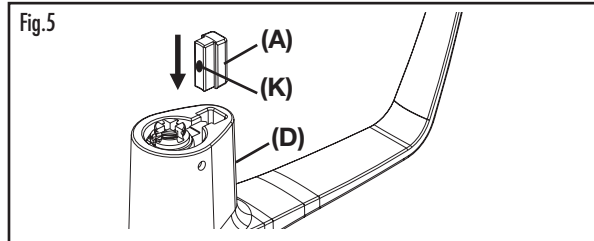

6. Insert key (C) into cylinder (B). Hold plug (A) in position

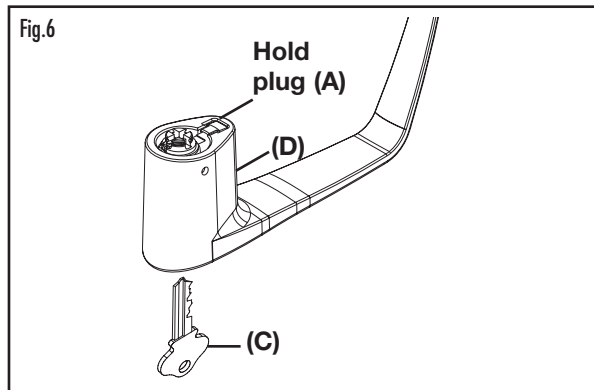

7. The key (C) must be in the horizontal position as shown below

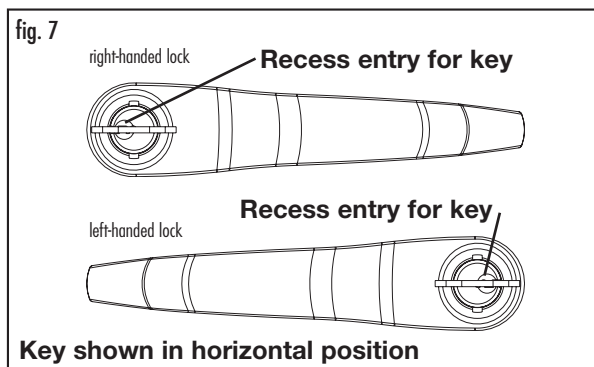

8. Turn the key approximately 100° clockwise for both right-handed and left-handed locks (Fig.8)

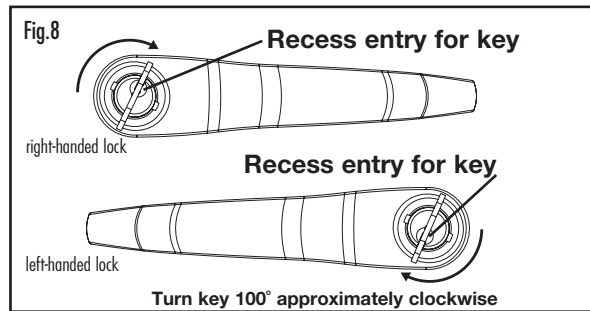

To attach the lever handle to the housing:

9. With the key (C) still in the position shown in Fig. 8, fit the lever handle (D) onto the drive tube (E). It should rest approximately 1/16" from the body of the housing. If not, wiggle or jiggle key (C) to align cylinder (B) with override shaft (F)

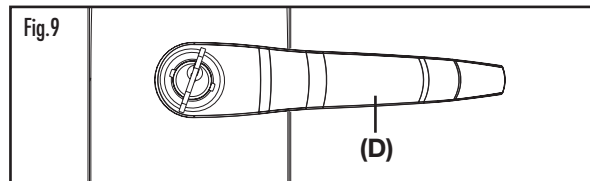

10. Press the lever (D) firmly against the housing while turning the key counterclockwise (**this applies to both right-handed and left-handed locks**) until it is in the horizontal position. (see fig.10)

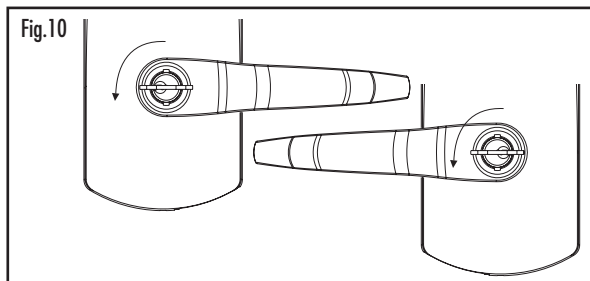

11. Remove the key. The recess entry for key should be in the position shown in Fig. 11

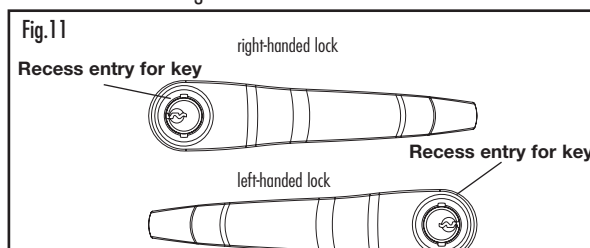

IMPORTANT:

To verify that you have properly attached the lever handle:

12. Without turning the lever handle, insert a small screwdriver or equivalent tool into the hole on the underside of the lever handle, (Fig. 12) and use it to push the lever catch (G) up.

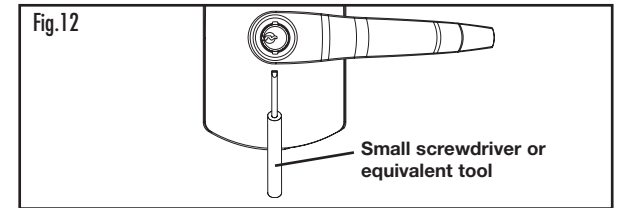

13. Pull on the lever handle. It should not come off of the housing. If it does, you have assembled the unit incorrectly and must start again, following the instructions on this page carefully.

14. If applicable, to reduce the lever play, using the 5/64 allen key (J), tighten the set screw (K) while pushing the lever against the front housing. Make sure the lever rotates properly after tightening the set screw (K) See fig 13.

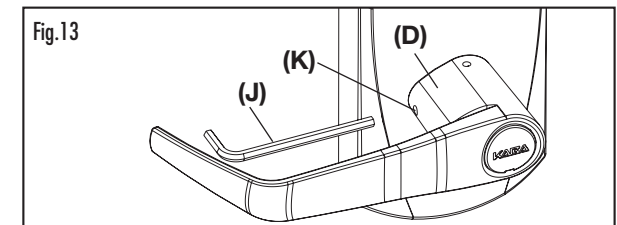

15. **Cover the keyhole & cylinder with the cap (I).** The cap (I) has a small groove on one edge (to allow ease of removal). This should be facing down. Insert bottom snap of cap (I) in handle hole below the cylinder. With a small screwdriver, push top snap of cap down while pushing the cap into place to cover the keyhole (Fig. 14).

